

**EN**

**INSTALLATION AND USE INSTRUCTIONS**  
Insulated immersion heaters mounted  
in capacity water heaters



***SELFA***

**GRZEJNICTWO ELEKTRYCZNE S.A.**

Before installing this electric heater, read and understand this  
Manual and the Warranty Terms & Conditions

## Table of Contents

1. General.....	2
2. Structure and specifications .....	2
3. Tank's volume-based heater's selection.....	4
4. Installation .....	4
5. Operation .....	6
6. Environmental Protection.....	7
7. Warranty Terms and Conditions.....	8

### 1. General

50... heaters are electrical heating devices designed for heating water in open and closed, enameled tanks of capacity heaters. Stainless steel heaters can also be used with stainless steel tanks (see the table in section 2).

### 2. Structure and specifications

SOURCE OF HEAT ENERGY: Tubular heating elements powered by single-phase 230V voltage. The thermostat with continuously adjustable temperature setting and non-automatic temperature limiter protects the heater from overheating:

- approximately  $77\pm 7^{\circ}\text{C}$  for the thermostat with a temperature range of  $8-60\pm 5^{\circ}\text{C}$
- approximately  $85\pm 7^{\circ}\text{C}$  for the thermostat with a temperature range of  $23-75\pm 5^{\circ}\text{C}$ .

The thermostat control dial and indicator light are located in the front faceplate. The lower part of the housing is attached to the G5/4" or G6/4" head with hexagon flats for S-60 wrench, which facilitates threading the heater into the female port on the tank. — **heater should not be screwed in by holding the plastic cover**. Technical data and the construction of the heaters are presented in the table and the figure below:

Material	Heater type / Size of the head thread					
	Cu *	50.157.412	50.207.412	50.307.412	50.157.212	50.207.212
Cu/Ni *	50.157.411	50.207.411	50.307.411	50.157.211	50.207.211	50.307.211
Stal nierdzewna	50.157.413	50.207.413	50.307.413	50.157.213	50.207.213	50.307.213
Incoloy 825	50.157.413.1	50.207.413.1	50.307.413.1	50.157.213.1	50.207.213.1	50.307.213.1
<b>Technical data</b>	G5/4"			G6/4"		
Rated voltage (V)	230/~50Hz					
Rated power (W)	1500	2000	3000	1500	2000	3000
Constrution	A	B	B	A	B	B
Dimension L (mm)	305	305	360	305	305	360
Weight (kg)	0,70	0,73	0,81	0,72	0,75	0,83
Degree of protection / thermostat temperature range	IP 44 / 23-77°C If the type of the heater additionally includes the letter "L" at the end, it indicates the use of a thermostat with a lower temperature range of 8-60°C					

**\* Do not use for stainless steel tanks (heaters made of copper – Cu and Cu/Ni)**

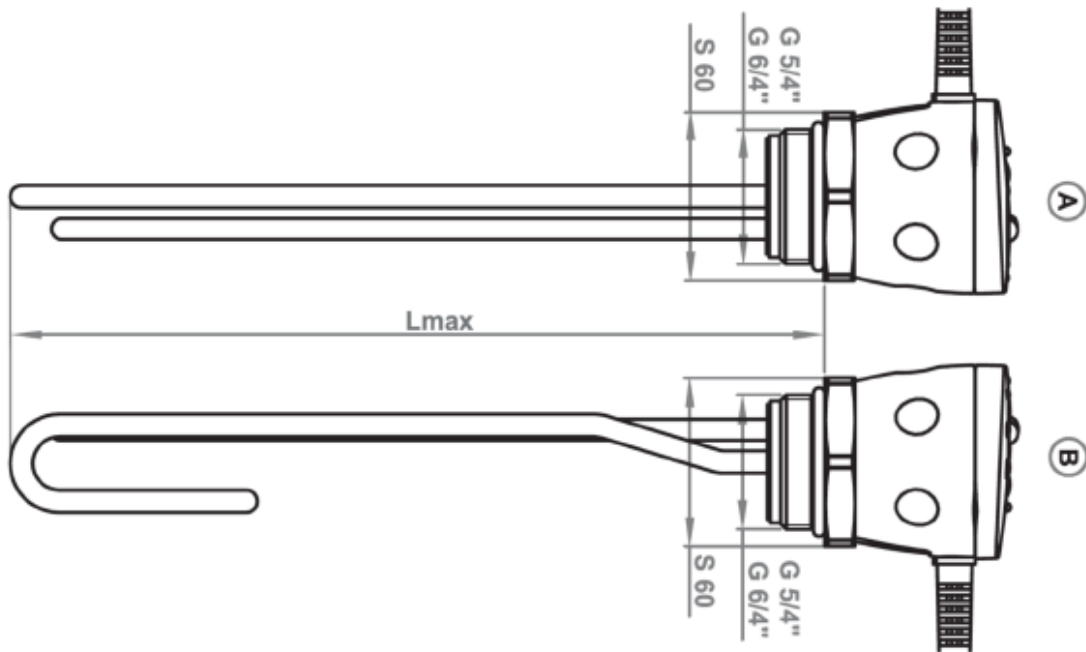

Cold zones  $L_m \sim 65\text{mm}$

### 3. Tank's volume-based heater's selection

Min. tank volume	60 dm <sup>3</sup>	80 dm <sup>3</sup>	120 dm <sup>3</sup>
Heater power	1500 W	2000 W	3000 W

### 4. Installation

The drawings below illustrate the correct positioning of the heater in the tank.

**Heaters can only be installed in a system where they are always positioned below the water level.**

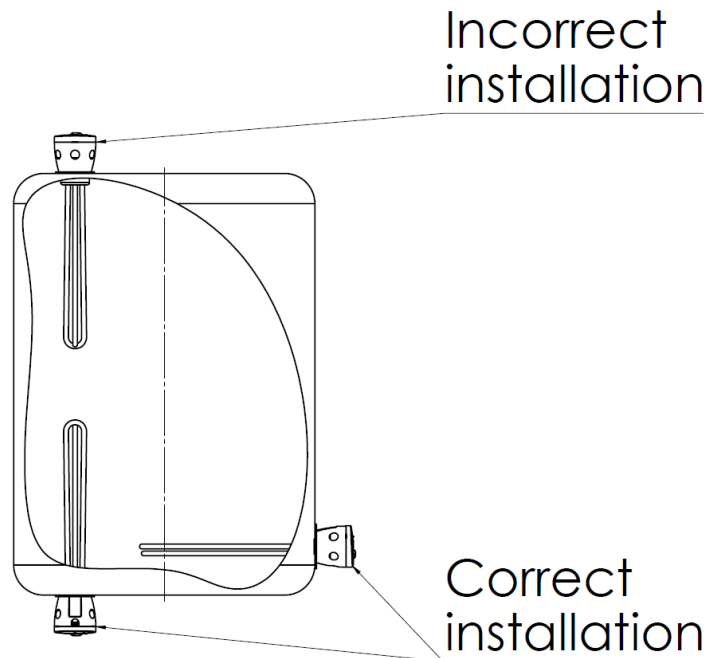

**Any other method of installation is not permitted**

The angular position of the heater when screwed in during horizontal installation.

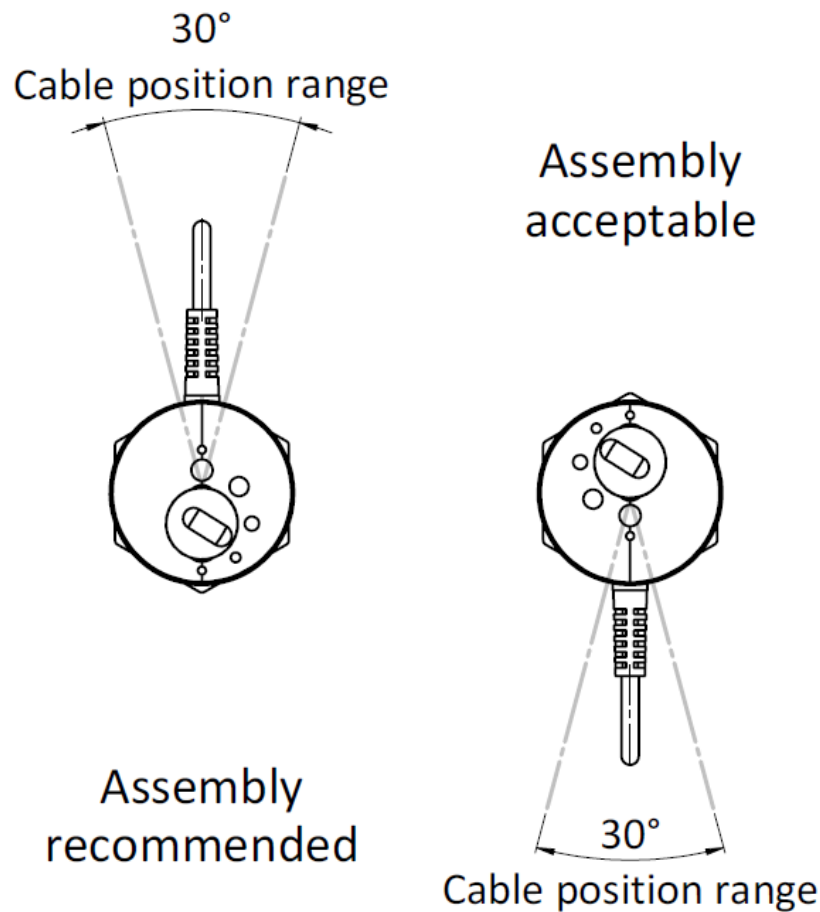

The installation of the heater must be carried out by a person with the appropriate qualifications required by the regulations in the given country, in accordance with the prevailing legal regulations regarding the safety of installation and use of such devices. When installing the heater, it is important to ensure that the heating elements fit inside the tank without touching its walls (minimum distance of 30 mm). The length of the fitting for mounting the heater cannot be longer than 60mm - **the fitting should not extend beyond the non-heating zone of the heater.**

The heater is designed for installation in pressurized DHW tanks and heating boilers with a maximum allowable pressure of 10 bar. All requirements for the installation, setup, and operation of these tanks must be met, including the mandatory installation of a **safety relief valve**. The tank must have a connection (fitting) with a thread size in accordance with the table in section 2. To install the heater, use a wrench to tighten it until a seal is achieved on the gasket. Be careful not to damage the gasket. Then, fill the tank and check for leaks.

## 5. Operation

Before inserting the plug into the 230V electrical socket, ensure that there is water in the tank and that the entire heater is submerged. If this condition is met, the heater can be connected. The socket should have an earthing contact (pin).

**Note: Connecting the heater to a power socket without grounding, in case of its damage, may result in electric shock.**

By turning the thermostat knob, the desired water temperature in the tank can be smoothly set within the range of up to  $75\pm 5^{\circ}\text{C}$  ( $60\pm 5^{\circ}\text{C}$  for types marked with the letter L). To increase the temperature, turn the knob counterclockwise.

### **Protection against overheating of the heating element.**

The non-automatic temperature limiter protects the heater from overheating in case of thermostat damage or water temperature exceeding  $85^{\circ}\text{C}$  ( $77^{\circ}\text{C}$  for the "L" version). Activation of the limiter may also occur if a second heat source is connected to the tank, heating the water above its operational parameters. In the event of limiter activation, the heater should be disconnected from the power, unplugged from the power socket, and the cause identified and rectified. Reconnection of power is only permissible after the heater has cooled down, and this can be achieved by pressing the button (red color) located on the body of the temperature limiter. To perform this action, the knob must be removed using a small screwdriver or rod (inserted into the designated hole under the knob), and the button should be pressed until the contacts engage.

### **OPERATING RECOMMENDATIONS:**

- **The length of the heater's service life is influenced by water parameters, such as the level of mineralization (hardness) of the water. The maximum acceptable concentration of chemical/mineral compounds (mg/l) in the heated water in the tank is:**
  - Chlorides - 250 mg/l,
  - Magnesium - 10 mg/l,
  - pH of water in the range from 6.5 to 9.5,
  - Sodium - 150 mg/l,
  - General water hardness ( $\text{CaCO}_3$ ) - a maximum of 250 mg/l.
  - Sulfates - 200 mg/l.
- **The heaters do not require attendance during operation.**

With hard water, however, the electric heating elements should be periodically cleaned of water scale, as it hinders the heat and ultimately may lead to heater failure.

- The removal of scale (boiler scale) by mechanical means is not allowed; it should be carried out with appropriate available agents (citric acid, descaling agents, etc.). Traces left by mechanical scale removal may result in the rejection of a warranty claim.
- When setting the DHW temperature in the DHW tank, it should be noted that a higher temperature setting increases the risk of water scale deposits and results in higher electrical power consumption.
- Heaters cannot be used in water containing chemical compounds, stray currents, or in an environment that may cause electrolytic corrosion, as this could lead to the rupture of the heater's protective tube.
- In tanks equipped with a titanium anode, the installation of heaters made of copper or copper with a nickel coating is not recommended. Heaters made of stainless steel AISI 316L or INCOLOY with heating elements galvanically isolated from the mounting head and the tank should be used for such tanks.
- The heater should operate at 230V – operating at elevated voltage may lead to faster burnout.

## 6. Environmental Protection

The product does not contain any environmentally harmful components. However, the used heating element should not be disposed of with household waste. This prohibition is indicated by the crossed-out container symbol located on the product or its packaging, as well as in the instructions.

In accordance with current regulations, electrical devices of this type, such as the heating element, should be delivered to a hazardous waste collection point. Information about the collection location and the method of disposal can be obtained from the relevant waste management authorities.

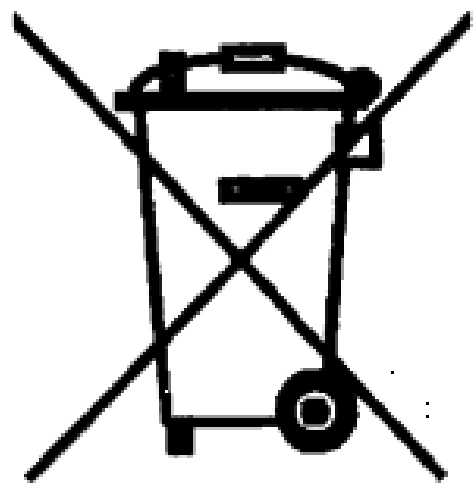

## 7. Warranty Terms and Conditions

1. The manufacturer ensures the proper functioning of the product provided it is correctly installed and used in accordance with the User Manual.
2. "SELFA" guarantees the user the good quality of the equipment and provides a warranty for a period of 24 months from the date of purchase, but no longer than 36 months from the date of production. The warranty is valid in the Republic of Poland (RP) and EU countries.
3. Any potential defects in the equipment arising from the manufacturer's fault during the warranty period will be repaired free of charge, provided it is delivered to "Selfa" GE S.A. along with the purchase document (invoice or receipt).
4. The manufacturer guarantees that warranty claims will be processed within 14 days from the day the product is received for repair.
5. All warranty claims from the RP territory should be reported using the complaint form on the website [www.selfa.pl](http://www.selfa.pl) - in the "Quality" tab and sent to the email address: [reklamacje@selfa.pl](mailto:reklamacje@selfa.pl). To report a warranty claim for a heater used outside the RP territory, you should contact the manufacturer's authorized commercial partner for the specific country or the point of sale of the heater.
6. The warranty period is extended by the time the equipment is left for repair.
7. The manufacturer is released from warranty responsibility (the warranty becomes invalid) in case of:
  - damage resulting from improper installation and use of the equipment in violation of the User Manual.
  - mechanical damage and defects resulting from such damage.
  - defects caused by unauthorized repairs and modifications.
  - damage caused by excessive scale build-up on heating elements.
  - traces on the product indicating dry operation (without water or in partial immersion) or operation in dirty water, such as sludge or mud, etc.
8. To expedite the service response, the manufacturer allows the possibility of considering warranty claims based on received photographs. The decision to consider such claims rests with the manufacturer.
9. This warranty on the sold equipment does not exclude, limit, or suspend the rights arising from the non-conformity of the goods with the contract concluded between the seller and the buyer.

Instruction manual number/version IOG 029/03

Release date: 2023-12-19