

INSTALLATION & OPERATION MANUAL
ZGT/ZGTi HEATERS
3x230V Y-connection power supply for domestic water
heaters (DHW heaters)

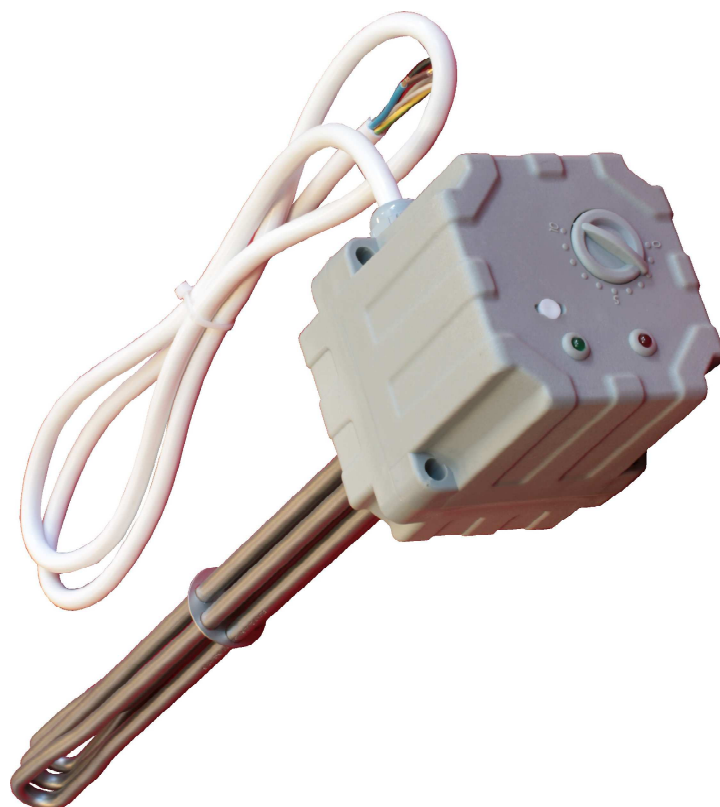

SELFA
GRZEJNICTWO ELEKTRYCZNE S.A.

Before installing this electric heater, read and understand this
Manual and the Warranty Terms & Conditions

Spis treści

1. General	2
2. Structure and specifications.....	3
3. Installation	4
4. Wiring to the mains.....	6
4.1 Wiring diagram of ZGTi heaters (insulated).....	6
4.2 Wiring diagram of ZGT heaters (non-insulated).....	7
5. Commissioning and operation	7
6. Environmental protection	10
7. Warranty Terms and Conditions	10

1. General

ZGT and ZGTi heaters are electrical heating devices designed for heating water in open and closed, enameled DHW tanks. Stainless steel heaters can be used with stainless steel tanks (see the table in section 2).

In ZGT heaters, heating elements are soldered directly into the mounting head.

ZGTi heaters are heaters with insulated heating elements. The insulation of heating elements is achieved by mounting them in a flange, isolated from the mounting head.

Isolation is used to eliminate the galvanic connection between the heating elements and the tank. To enhance the cathodic protection of the tank in ZGTi heaters, a properly selected resistor is used. This causes the difference in electrochemical potentials between the heating element and the carbon steel tank to be partially offset. This significantly increases the durability of the heating elements and the service life of the magnesium anode.

2. Structure and specifications

ZGT and ZGTi heaters are constructed with tubular heating elements powered by a voltage of 3 x 230 V, along with a thermostat featuring stepless temperature control and a temperature limiter to protect the heater from overheating. The thermostat control dial and indicator lights are located in the front faceplate. The lower part of the housing body ends with a 1½” thread metal head with hexagon flats for S-60 wrench, which facilitates threading the heater into the female port on the tank. The design of heaters and their technical data is shown in the figure and in the table below:

Heater type	Group	Power	Voltage	Dead zone length	Head material	Threaded connection	Minimum Tank capacity
		[kW]	[V]	[mm]		[cal]	[dm ³]
44.130.X*	ZGTi	3,0	3 x 230 Y	~115	Brass	1 ½”	80
44.145.X*	ZGTi	4,5	3 x 230 Y	~115	Brass	1 ½”	100
44.160.X*	ZGTi	6,0	3 x 230 Y	~115	Brass	1 ½”	100
44.190.X*	ZGTi	9,0	3 x 230 Y	~115	Brass	1 ½”	250
44.330.X*	ZGTi	3,0	3 x 230 Y	~115	AISI 304	1 ½”	80
44.345.X*	ZGTi	4,5	3 x 230 Y	~115	AISI 304	1 ½”	100
44.360.X*	ZGTi	6,0	3 x 230 Y	~115	AISI 304	1 ½”	100
44.390.X*	ZGTi	9,0	3 x 230 Y	~115	AISI 304	1 ½”	250
44.430.X*	ZGT	3,0	3 x 230 Y	~95	AISI 304	1 ½”	80
44.445.X*	ZGT	4,5	3 x 230 Y	~95	AISI 304	1 ½”	100
44.460.X*	ZGT	6,0	3 x 230 Y	~95	AISI 304	1 ½”	100
44.490.X*	ZGT	9,0	3 x 230 Y	~95	AISI 304	1 ½”	250
44.412.X*	ZGT	12,0	3 x 230 Y	~95	AISI 304	1 ½”	300

* the 6th digit means:

- 4 - AISI 316L heater housing tube
- 5 - Cu/Ni heater housing tube – **do not use with stainless steel tanks**
- 6 - Cu heater housing tube – **do not use with stainless steel tanks**
- 7 - Incoloy 825 heater housing tube

The above table contains standard heater types, but there can also be eight -or nine-digit types. This means they are modified versions of the standard type. For example, **44.160.4.001** is a modified version of heater **44.160.4**.

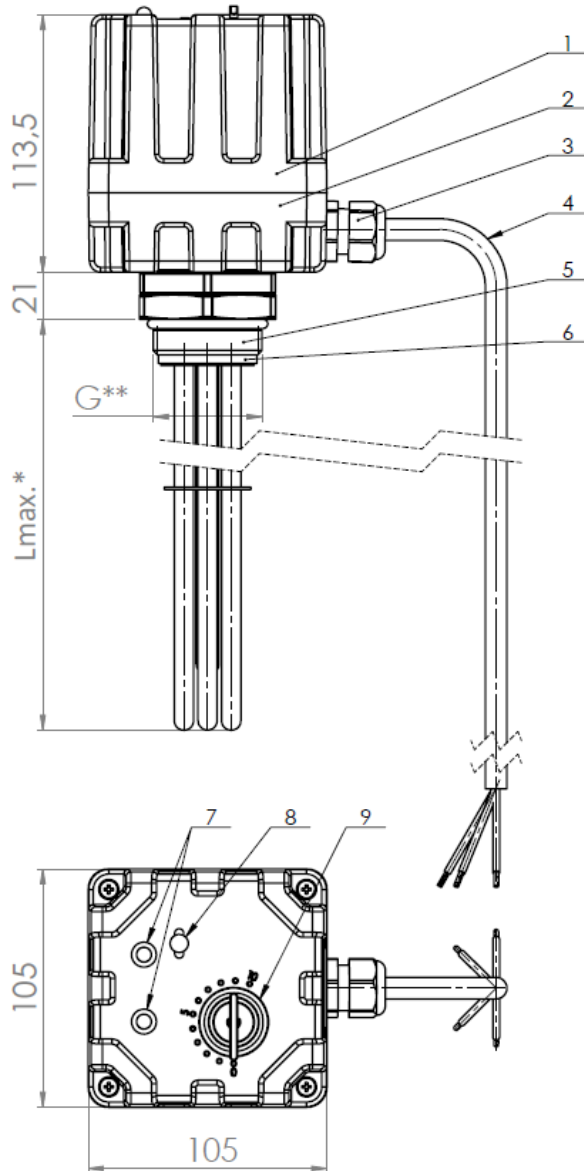

1. Faceplate/cover
2. Housing body
3. Gland
4. Power cable
L=1700mm
5. Heating elements
6. Gasket for isolating the heating element from the head (non-insulated ZGT heaters do not have a gasket)
7. Indicator LEDs for the heater operation and power connection
8. Plug for resetting the temperature limiter
9. Thermostat's control dial

*Maximum immersion depth - Lmax - specified on the nameplate of the heater, located on the cover of the housing.

** Thread size - specified on the nameplate of the heater, located on the cover of the housing.

3. Installation

See the figure for the correct operating orientation of the heater after installation in the DHW tank.

Heaters can only be installed in a system where they are always positioned below the water level

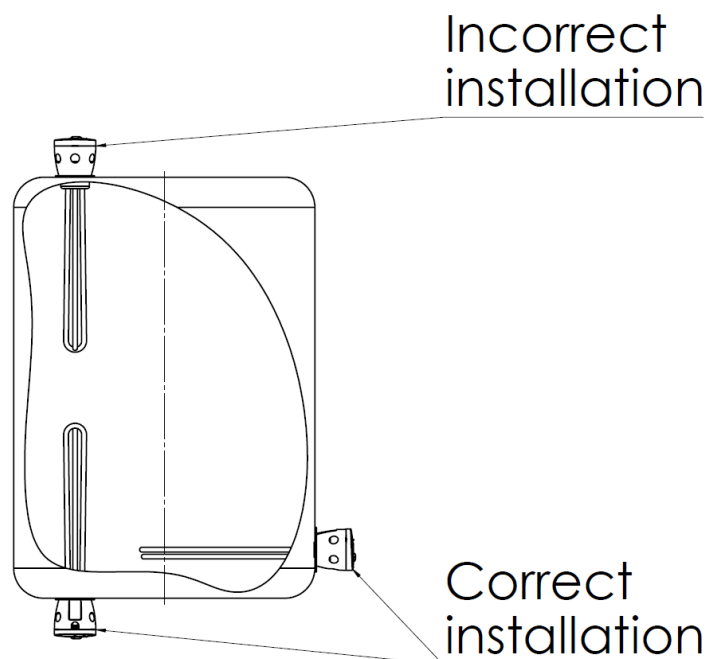

Any other method of installation is not permitted

The installation of the heater must be carried out by a person with the appropriate qualifications required by the regulations in the given country, in accordance with the prevailing legal regulations regarding the safety of installation and use of such devices. When installing the heater, it is important to ensure that the heating elements fit inside the tank without touching its walls (minimum distance of 30 mm). The length of the fitting for mounting the heater must be at least 5 mm shorter than the non-heating zone of the heater (see the table in section 2) - **the fitting should not extend beyond this zone.**

The heater is designed for installation in pressurized DHW tanks and heating boilers with a maximum allowable pressure of 10 bar. All requirements for the installation, setup, and operation of these tanks must be met, including the mandatory installation of a **safety relief valve**. The tank must have a connection (fitting) with a thread size in accordance with the table in section 2. To install the heater, use a wrench to tighten it until a seal is achieved on the gasket. Be careful not to damage the gasket. Then, fill the tank and check for leaks.

Provide service access to the power cable plug or mains switch once the electric heater has been installed

SELFA GE S.A.

ul. Bieszczadzka 14, 71-042 Szczecin, Polska
 tel. +48 91 81 46 300
 fax +48 91 81 46 354
 info@selfa.pl • www.selfa.pl

NIP 852-22-99-864
 REGON 812026229
 KRS 0000004595
 Kapitał akcyjny: 800 000 PLN



N A T O COMMERCIAL AND GOVERNMENT ENTITY CODE 1213H



4. Wiring to the mains

The heaters are factory-supplied with five-core power cables without a plug. The free end of this cable should be connected to a three-phase installation with a line voltage of 3 x 400 V using a plug with **five pins** and the appropriate socket or a connector that ensures complete disconnection on all poles in accordance with the applicable regulations for surge protection of devices and electrical installations.

4.1 Wiring diagram of ZGTi heaters (insulated)

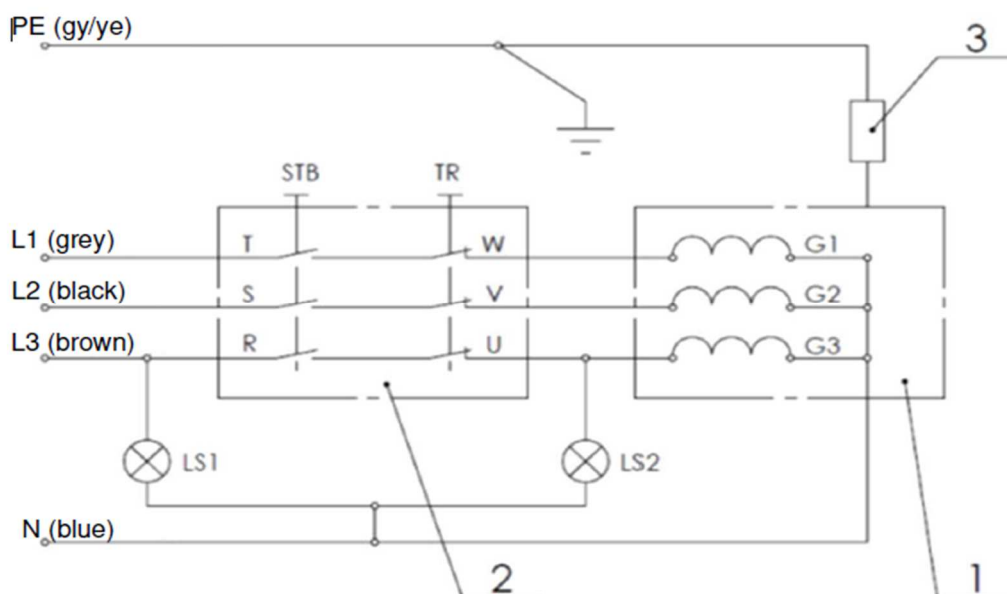

4.2 Wiring diagram of ZGT heaters (non-insulated)

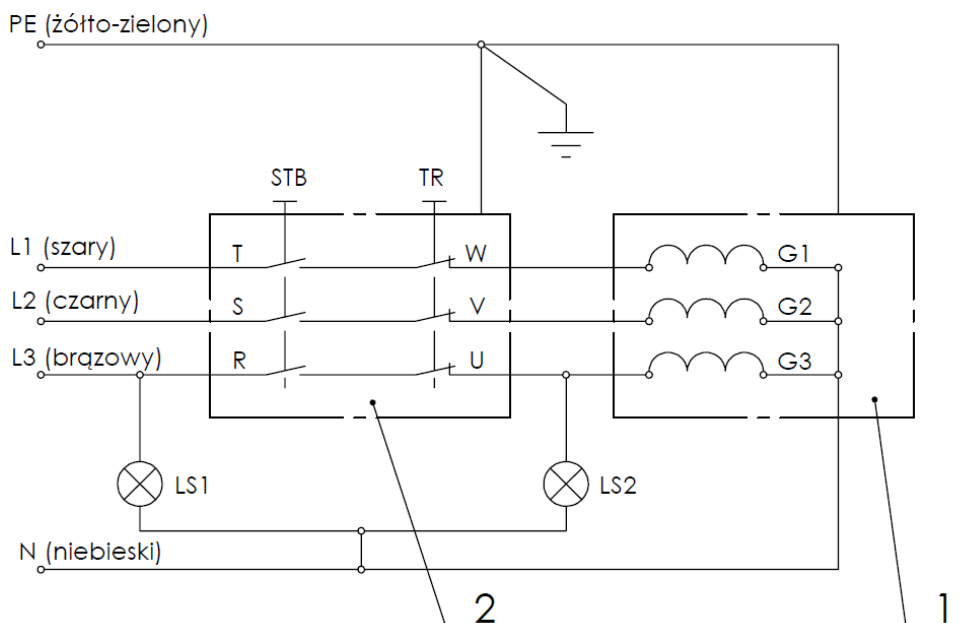

1. Heating element cluster
 2. Thermostat + temperature limiter
 3. Resistor
- LS1 – green indicator light
 LS2 – red indicator light

5. Commissioning and operation

After turning on the power supply (with the mains switch or by plugging the power cable into a mains socket), both control indicator lights on the cover of the housing should illuminate:

- green - indicating that the power is on;
- red - indicating the heating element is on live voltage.

If the thermostat dial is in the far left position and the red indicator does not come on, turn the dial clockwise until the thermostat contacts make.

It is recommended that the water charge is first heater with monitoring the DHW heater – the volume of water increasing in the pressurized tank with the heat input must be discharged outside through the safety relief valve or collected in a membrane expansion vessel.

The power cycling of the electric heater as the DHW cools down or is





taken from the DHW tank is managed by the thermostat interfaced with a capillary tube sensor in a dedicated sheath, which is immersed in water. By operating the thermostat dial (see the table below), the desired water temperature in the DWH tank can be steplessly set from $+7.5\pm 6^{\circ}\text{C}$ to $+75\pm 3^{\circ}\text{C}$ (with the dial in the far right position). When the DHW temperature matches the thermostat control setting, the thermostat automatically turns off the power to the heating elements and will switch the power back on when the DHW temperature falls below the setting.

Overtemperature protection

A non-automatic temperature limiter provides protection of the electric heater against overheating by isolating the power supply to the electric heater cluster if the thermostat fails and the water temperature exceeds $98(0/-8)^{\circ}\text{C}$. The power supply can be reconnected only when the electric heater cools down below the limiter trip setting and the trip reset button is pressed on the temperature limiter enclosure. To do this, remove the cap (number 9 in the diagram) located on the electric heater housing plate and use a small flat screwdriver or a similar tool to press the trip reset button (first unplug the heater from the mains or turn off the mains switch. This operation shall only be attempted by suitably qualified personnel which has identified the root cause of the failure and will remedy it.

Frost protection

The thermostat used in the heater includes a freeze protection function to maintain the water temperature in the DHW tank at approximately $+7.5\pm 6^{\circ}\text{C}$. This function can be activated by turning the thermostat dial to the far left. This dial position is not for turning off the heater, it is solely for freeze protection.

3-phase heater	Approx. temperature Thermostat dial position
	Far left – frost protection enabled: the electric heater turns on only when the DWH temperature drops to $+7,5\pm 6^{\circ}\text{C}$
	Approx. $+30^{\circ}\text{C}$, no risk of water scale deposits
	Approx. $+45^{\circ}\text{C}$, slight risk of water scale deposits
	$+75\pm 3^{\circ}\text{C}$, elevated risk of water scale deposits

OPERATING RECOMMENDATIONS:

- The water parameters, such as the level of mineralization (hardness) of the water, have an impact on the lifespan of the heater. The maximum acceptable concentration of chemical/mineral compounds (mg/l) in the water heated in the tank is:
 - Chlorides - 250 mg/l,
 - Magnesium - 10 mg/l,
 - pH of the water in the range from 6.5 to 9.5,
 - Sodium - 150 mg/l,
 - Total water hardness (CaCO₃) - up to 250 mg/l,
 - Sulfates - 200 mg/l.
- The heaters do not require attendance during operation. With hard water, however, the electric heating elements should be periodically cleaned of water scale, as it hinders the heat and ultimately may lead to heater failure.
- The removal of scale (boiler scale) by mechanical means is not allowed; it should be carried out with appropriate available agents (citric acid, descaling agents, etc.). Traces left by mechanical scale removal may result in the rejection of a warranty claim.

- When setting the DHW temperature in the DHW tank, remember that the higher a temperature setting, the higher risk of water scale deposits and higher electrical power consumption.
- Do not use in water containing chemical compounds, stray currents, or in an environment that may cause electrolytic corrosion, as this could result in the rupture of the protective sheath of the heater.
- In tanks equipped with a titanium anode, do not install heaters made of copper or copper with a nickel coating. For such tanks, use heaters made of stainless steel AISI 316L or INCOLOY with heating elements galvanically isolated from the mounting head and tank.

6. Environmental protection

The product does not contain any environmentally harmful components. However, the used heating element should not be disposed of with household waste. This prohibition is indicated by the crossed-out container symbol located on the product or its packaging, as well as in the instructions.

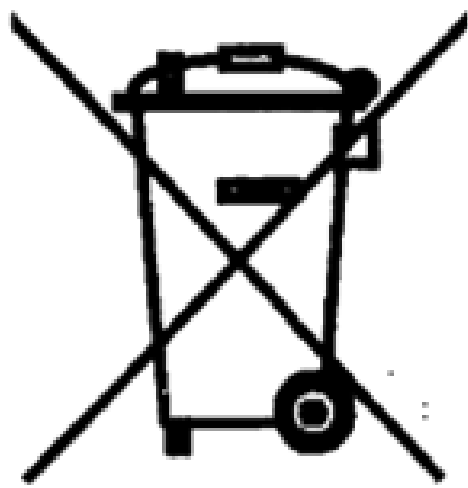

In accordance with current regulations, electrical devices of this type, such as the heating element, should be delivered to a hazardous waste collection point. Information about the collection location and the method of disposal can be obtained from the relevant waste management authorities.

7. Warranty Terms and Conditions

1. The manufacturer ensures the proper functioning of the product provided it is correctly installed and used in accordance with the User Manual.
2. "SELFA" guarantees the user the good quality of the equipment and provides a warranty for a period of 24 months from the date of purchase, but no longer than 36 months from the date of production. The warranty is valid in the Republic of Poland (RP) and EU countries.

3. Any potential defects in the equipment arising from the manufacturer's fault during the warranty period will be repaired free of charge, provided it is delivered to "Selfa" GE S.A. along with the purchase document (invoice or receipt).
4. The manufacturer guarantees that warranty claims will be processed within 14 days from the day the product is received for repair.
5. All warranty claims from the RP territory should be reported using the complaint form on the website www.selfa.pl - in the "Quality" tab and sent to the email address: reklamacje@selfa.pl. To report a warranty claim for a heater used outside the RP territory, you should contact the manufacturer's authorized commercial partner for the specific country or the point of sale of the heater.
6. The warranty period is extended by the time the equipment is left for repair.
7. The manufacturer is released from warranty responsibility (the warranty becomes invalid) in case of:
 - damage resulting from improper installation and use of the equipment in violation of the User Manual.
 - mechanical damage and defects resulting from such damage.
 - defects caused by unauthorized repairs and modifications.
 - damage caused by excessive scale build-up on heating elements.
 - traces on the product indicating dry operation (without water or in partial immersion) or operation in dirty water, such as sludge or mud, etc.
8. To expedite the service response, the manufacturer allows the possibility of considering warranty claims based on received photographs. The decision to consider such claims rests with the manufacturer.
9. This warranty on the sold equipment does not exclude, limit, or suspend the rights arising from the non-conformity of the goods with the contract concluded between the seller and the buyer.

Instruction manual number/version IOG 031/02
 Release date: 2023-11-08

SELFA GE S.A.

ul. Bieszczadzka 14, 71-042 Szczecin, Polska
 tel. +48 91 81 46 300
 fax +48 91 81 46 354
 info@selfa.pl • www.selfa.pl

NIP 852-22-99-864
 REGON 812026229
 KRS 0000004595
 Kapitał akcyjny: 800 000 PLN

